



STADLER INNOVÁCIÓ MAGYAR SÍNEKEN TRAMTRAIN ÉS ETCS

Horváth Keve, Siófok, 10.12.2018

STADLER



DIVÍZIÓK

STADLER RAIL GROUP

SWITZERLAND



Bussnang 1900 EMP

GERMANY



Pankow 1000 EMP

CENTRAL EUROPE



Siedlce (PL) 800 EMP

SPAIN



Valencia 900 EMP

COMPONENTS



Winterthur (CH) 260 EMP

SERVICE



Switzerland 70 EMP



Altenrhein 950 EMP



Velten 40 EMP



Prague (CZE) 60 EMP



ERION 30 EMP
ERION (F) 20 EMP



Bienne (CH) 110 EMP

Austria 20 EMP

Algeria 100 EMP

Hungary 72 EMP

Italy 10 EMP

The Netherlands 80 EMP

Poland 30 EMP

Sweden 20 EMP

Stadler UK 10 EMP



Salt Lake City (USA)
80 EMP



Reinickendorf 60 EMP



Minsk (BLR) 450 EMP



Szolnok (HUN) 430 EMP



Chemnitz 60 EMP



Środa (PL) 250 EMP

Termelő egységek 7 országban, 11 államot lefedő szervízhálózat, vonatok a világ 30 országában

A STADLER MAGYARORSZÁGON

VÁLLALATOK ÉS TEVÉKENYSÉGEK

Stadler Budapest



Stadler központi iroda

- Sales tevékenység
- PR és marketing
- Stratégiai project management
- 7 munkatárs

Stadler Pusztaszabolcs



Preventív és korrekív karbantartás

- MÁV FLIRT karbantartás 30 évre
- Kerékszterga
- 3. féltől érkező megbízások (GYSEV, HÉV)
- 45 munkatárs

Stadler Szolnok



Production

- Alumínium kocsiszekrény gyártás
- CNC megmunkálás
- Homokszórás és festés
- Munkatársak száma: 430
- Maximum kapacitás: 400 kocsiszekrény

BRCC



Bogie revision competence center (BRCC)

- MÁV FLIRT motorvonatok
- Stadler Meran, Stadler Polska, Stadler Pankow etc.
- 3. féltől érkező megrendelések
- 27 munkatárs



SALES FIGURES

HAZÁNKBAN FUTÓ JÁRMŰVEINK



2005

30 FLIRT MÁV



2007

30 FLIRT MÁV



2012

4 FLIRT GYSEV



2013

42 FLIRT MÁV



2013

6 FLIRT EMUs for GYSEV



2015

21 FLIRT MÁV



2016

10 FLIRT3 GYSEV



2017

11 KISS MÁV



2017

8 Citylink MÁV



2018

8 KISS MÁV

191 egység 2018-ig:
143 hagyományos és 40 emeletes motorvonat
valamint 8 tram-train 13 év alatt

SALES FIGURES

HAZÁNKBAN FUTÓ JÁRMŰVEINK



2005

30 FLIRT MÁV



2007

30 FLIRT MÁV



2012

4 FLIRT GYSEV



2013

42 FLIRT MÁV



2013

6 FLIRT EMUs for GYSEV



2015

21 FLIRT MÁV



2016

10 FLIRT3 GYSEV



2017

11 KISS MÁV



2017

8 Citylink MÁV



2018

8 KISS MÁV

191 egység 2018-ig:
143 hagyományos és 40 emeletes motorvonat
valamint 8 tram-train 13 év alatt

A STADLER CITYLINK TRAMTRAIN MAGYARORSZÁGON







CITYLINK

ESÉLYEGYENLŐSÉG

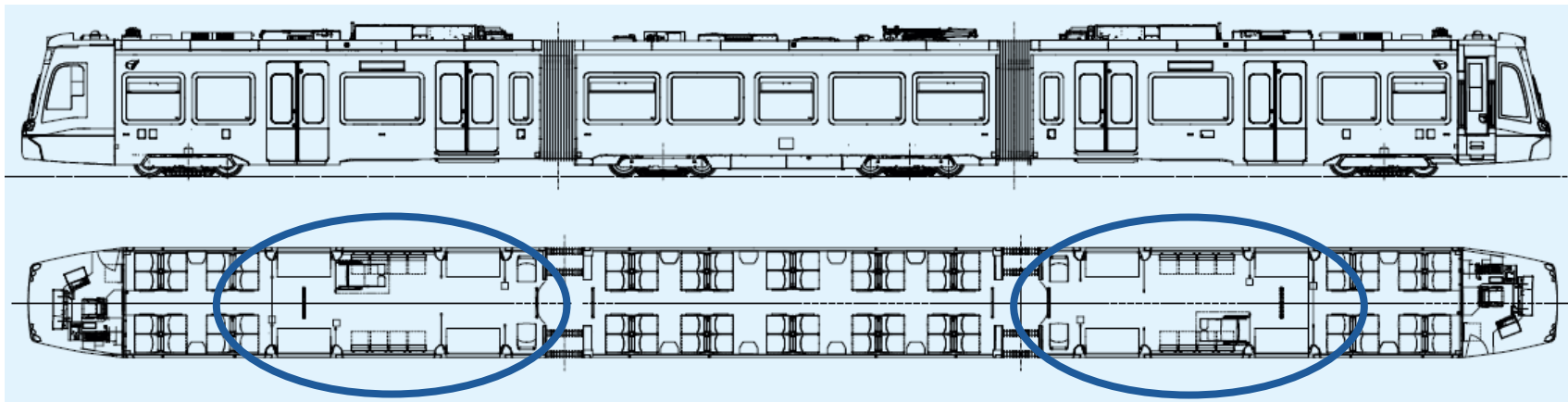

CITYLINK

ESÉLYEGYENLŐSÉG

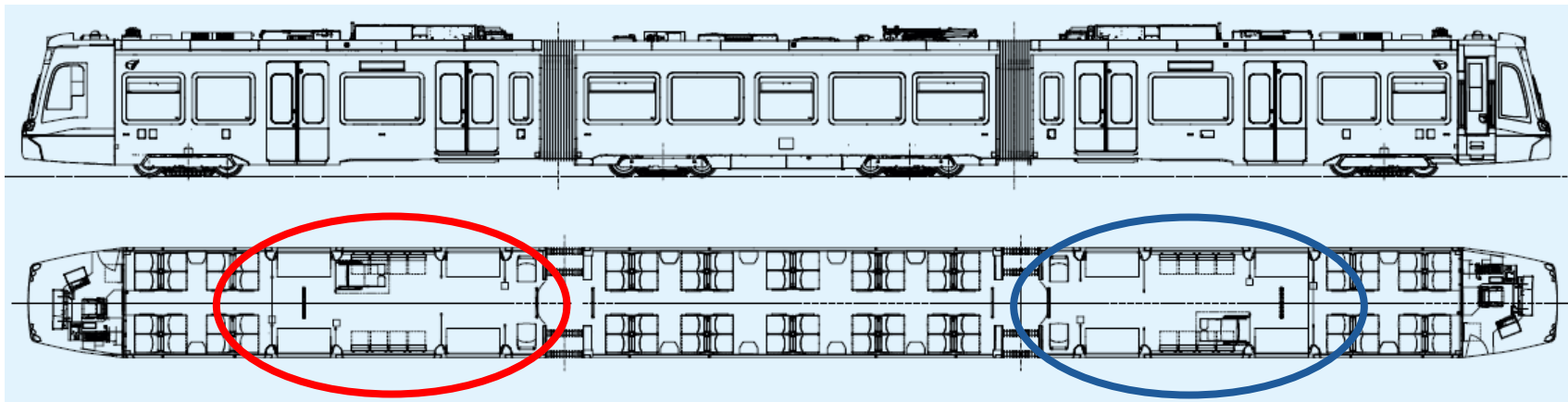

CITYLINK

FORGÓVÁZ KIALAKÍTÁS

- A legalacsonyabb, hagyományos kialakítású forgóváz kategóriájában
- Nagyvasúti műszaki megoldások villamos vasúti méretben
- Nagyon jó futási paraméterek 110km/h sebességig
- 22m-es legkisebb bejárható ívsugár
- Nyugodt futás a másodlagos légrugóknak köszönhetően



CITYLINK TECHNOLOGIA

MODULÁRIS VEZETŐÁLLÁS KONCEPCIÓ

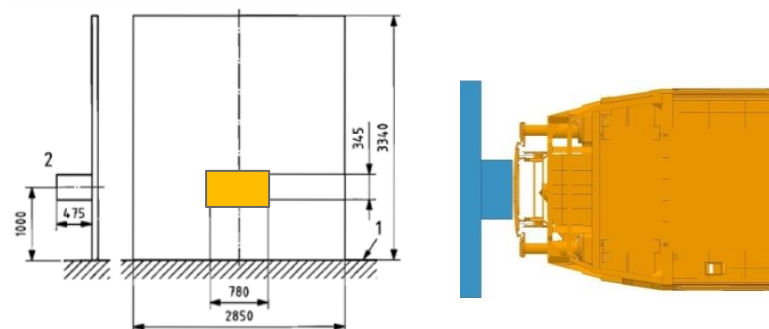
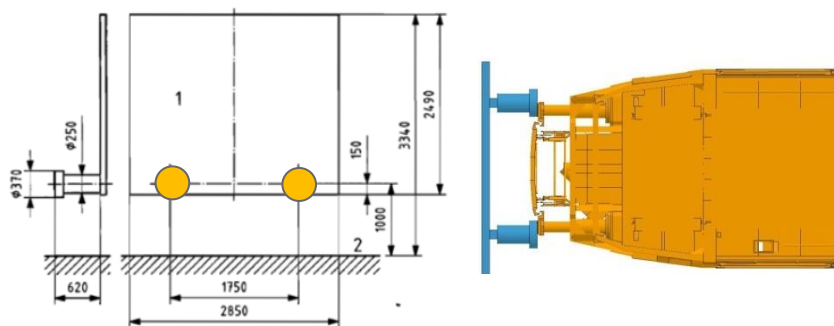

CITYLINK TECHNOLOGIA

BIZTONSÁGOS KILÁTÁS

- Ergonomikus vezetőállás, amely megfelelő kilátást biztosít városi környezetben is
- DIN 5566-3 szabványnak megfelel

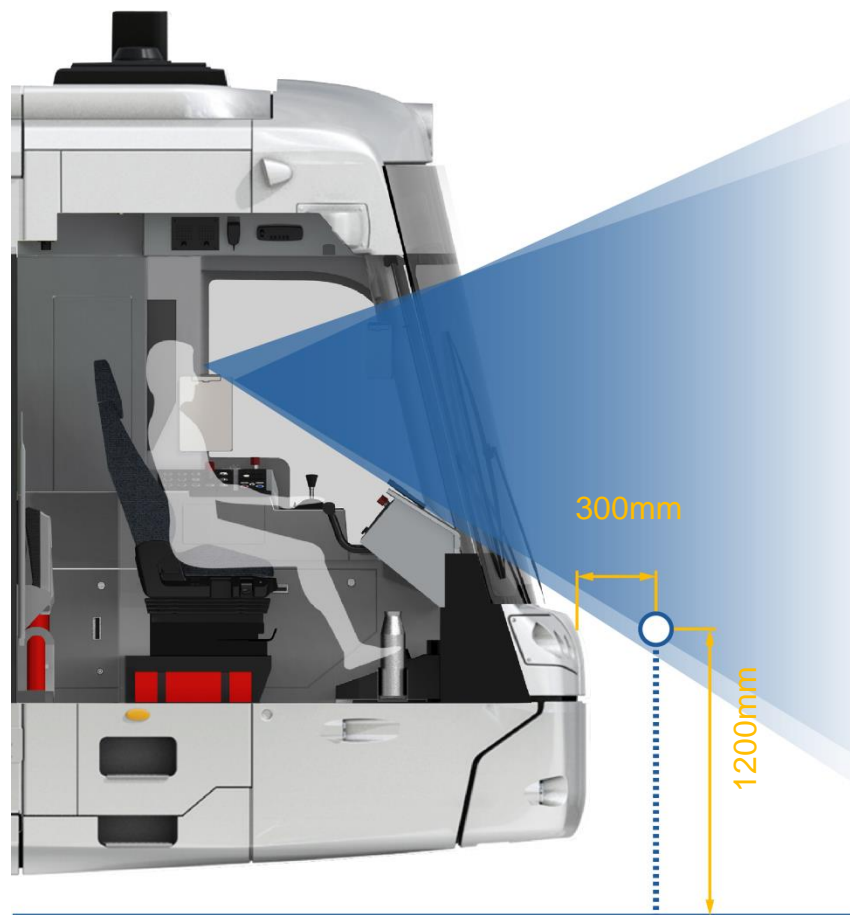
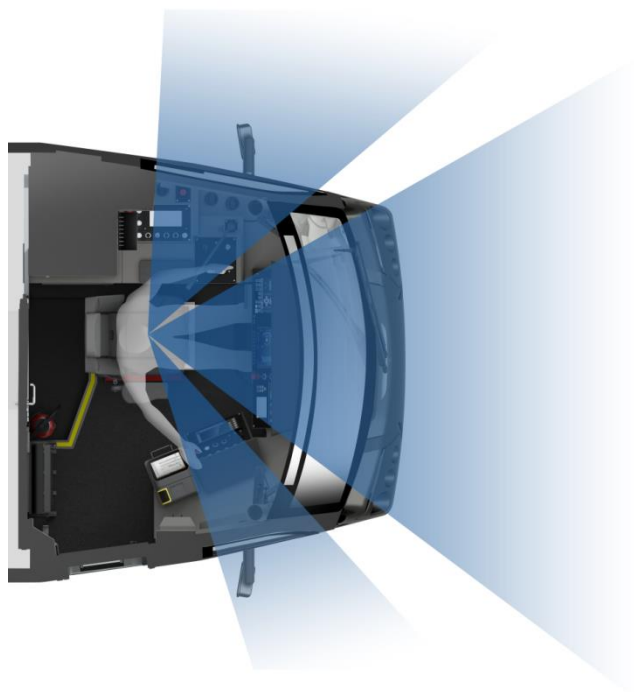

CITYLINK – IGAZODIK AZ IGÉNYEKHEZ

BELSŐ ELRENDEZÉS

– Sheffield

235pax @ 4p/m²



– Chemnitz

228pax @ 4p/m²



– Karlsruhe

240pax @ 4p/m²



– Szeged

216pax @ 4p/m²

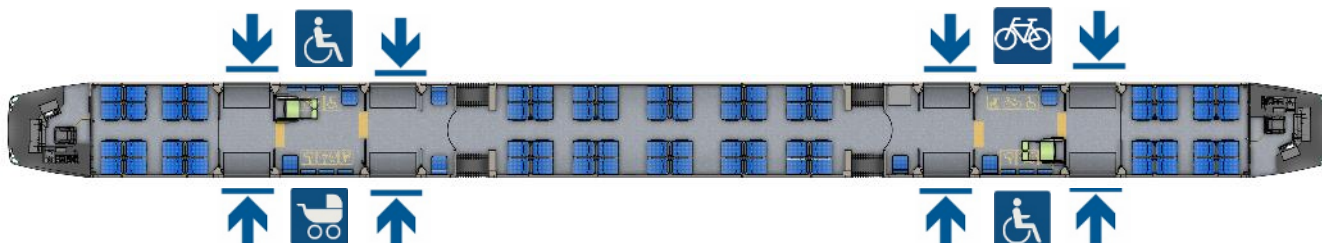

CITYLINK - IGAZODIK AZ IGÉNYEKHEZ

VONTATÁSI ENERGIA ELLÁTÁS

750V dc vagy 1500V dc

- Alicante (1000 mm)
- Mallorca (1000 mm)
- Karlsruhe (1435 mm)

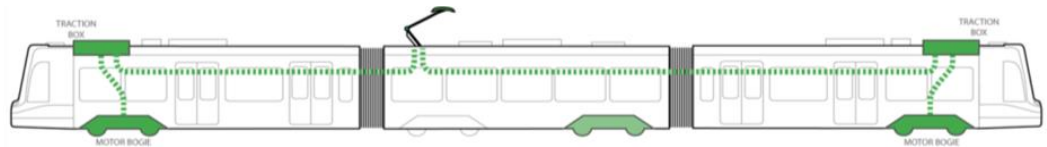

Dízel

- FEVE, Spanyolo. (1000 mm)
- Puebla, Mexico (1435 mm)

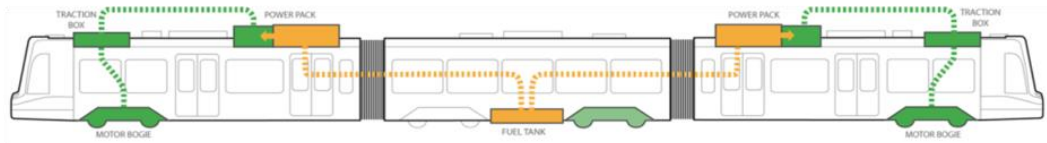

Diesel + 600/750Vdc (Hibrid)

- Chemnitz (1435 mm)
- **Szeged, (1435 mm)**
- Alicante (1000 mm)

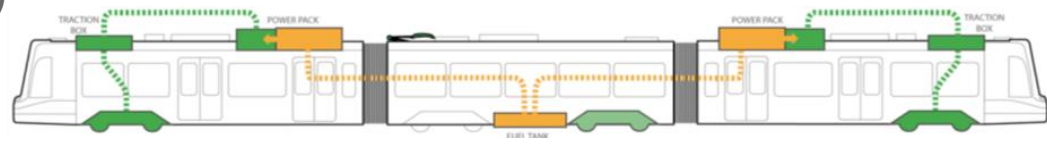

750Vdc + 25KVa

- Sheffield, UK (1435 mm)

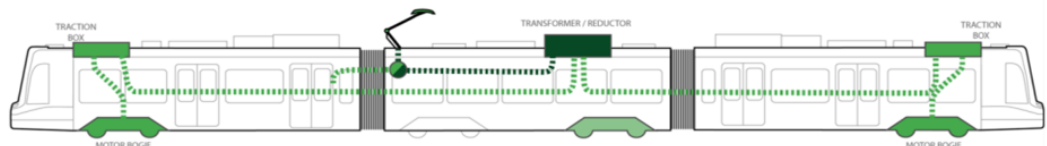

Az energiaellátó rendszer igazodik a meglévő infrastruktúrához

CITYLINK ÜZEMELTETŐK



9

FGV Alicante, Spanyolország



75

VBK & AVG Karlsruhe, Németország



8

MAV START Zrt., HU



12

VMS Chemnitz, Németország



2

Puebla, Mexico



6

FGV, Spanyolország



7

Sheffield, UK



6

SFM, Spanyolország



36

W&B, UK

Közel 200 jármű 5 országban

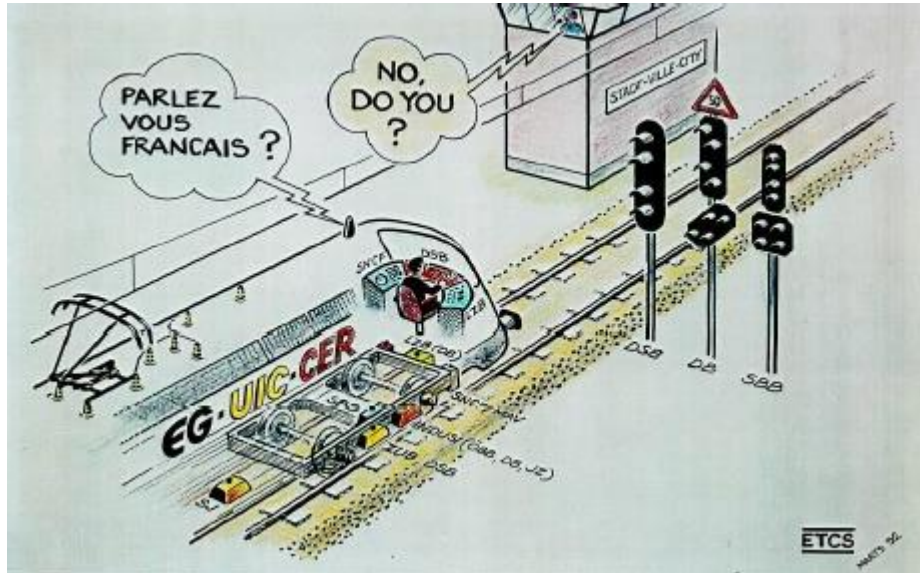

GUARDIA – A STADLER ETCS MEGOLDÁSA

STADLER

ÁTALAKULÁS A VASÚTI PIACON

A SIEMENS-ALSTOM FÚZIÓ

Új európai piaci helyzet alakult volna ki a Siemens és Alstom vasúti üzletágának egyesülésével



PIACI RÉSZESEDÉSEK

JÁRMŰFEDÉLZETI ETCS EURÓPÁBAN

Járműfedélzeti ETCS eladások 2011 óta

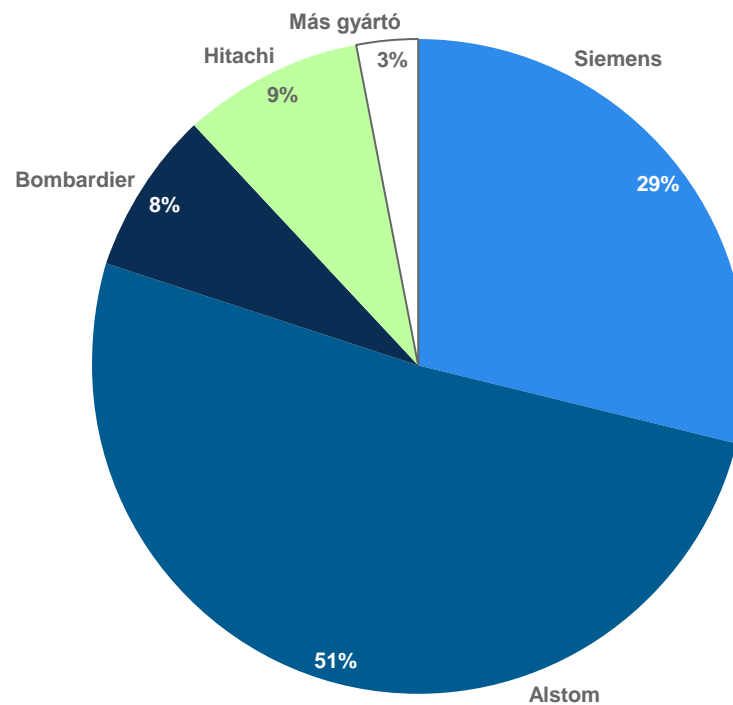

Berücksichtigt Bestellungen ab 2011, Marktanteile gemäss totale Anzahl gelieferte Geräte seit 2011
Quelle: Webseite ERTMS

STADLER BIZTOSÍTÓBERENDEZÉS

ÜZLETPOLITIKA

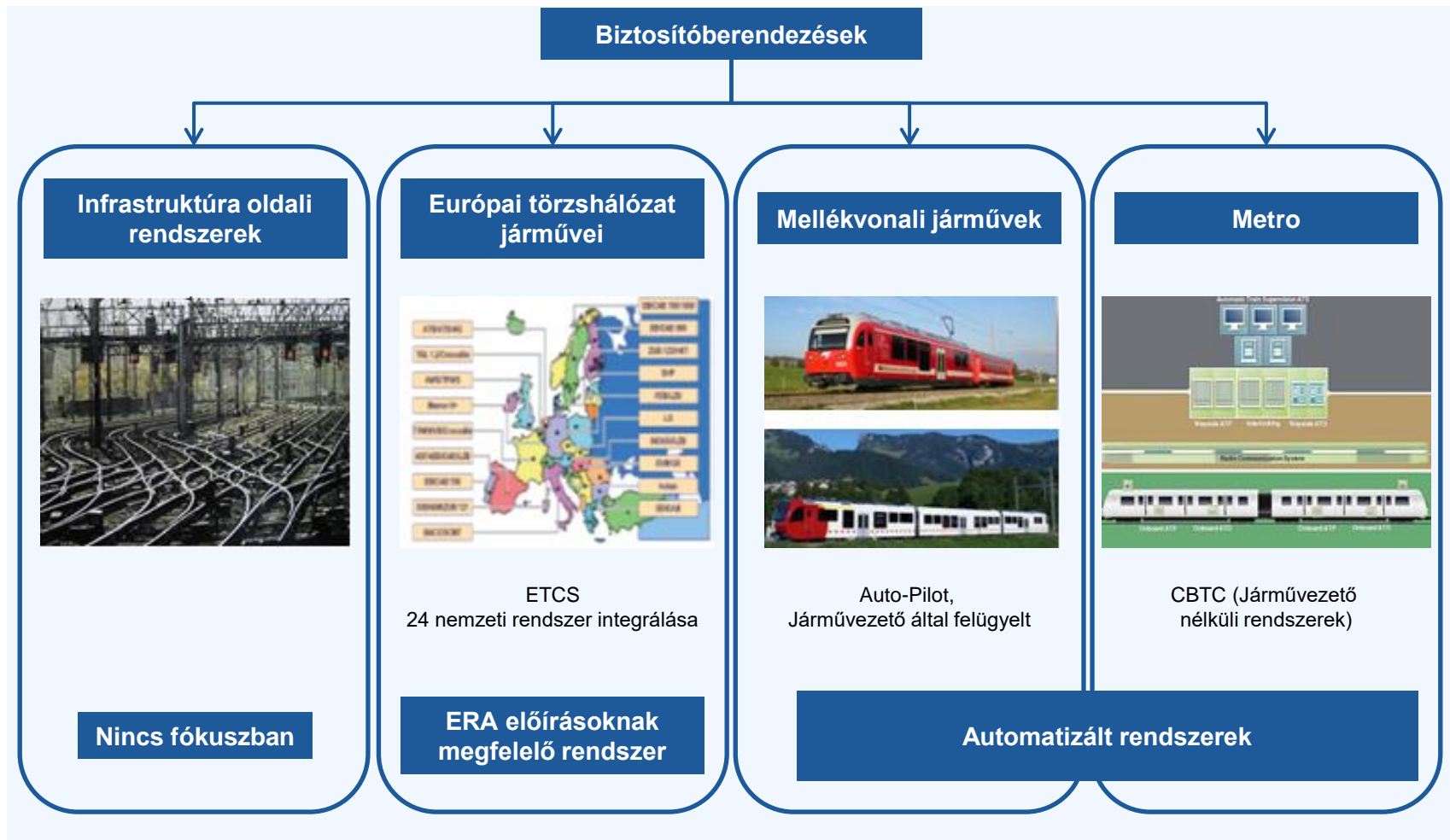

STADLER BIZTOSÍTÓBERENDEZÉS ÜZLETPOLITIKA

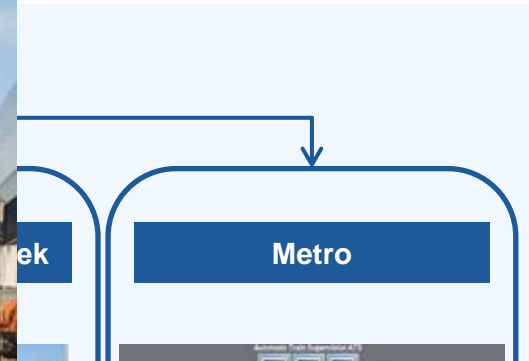

ETCS
24 nemzeti rendszer integrálása

Nincs Fókuszban

Alternatív megoldás a
bővülő piac számára

ÚJ VEGYESVÁLLALAT

STADLER - ANGELSTAR



Angelo Investments
SYNERGIC HIGH-TECH COMPANIES WITH ABOUT 1'000 EMPLOYEES

AngelStar

**«Guardia»
Stadler ETCS
System**



mermec
RAILWAY

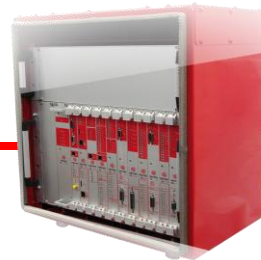

STADLER

UNISIG
SUPPLIERS

ALSTOM

CAF

AnsaldoSTS

mermec group



SIEMENS

BOMBARDIER

THALES

© UNIFE 2014

A BERENDEZÉS RŐL DIÓHÉJBAN

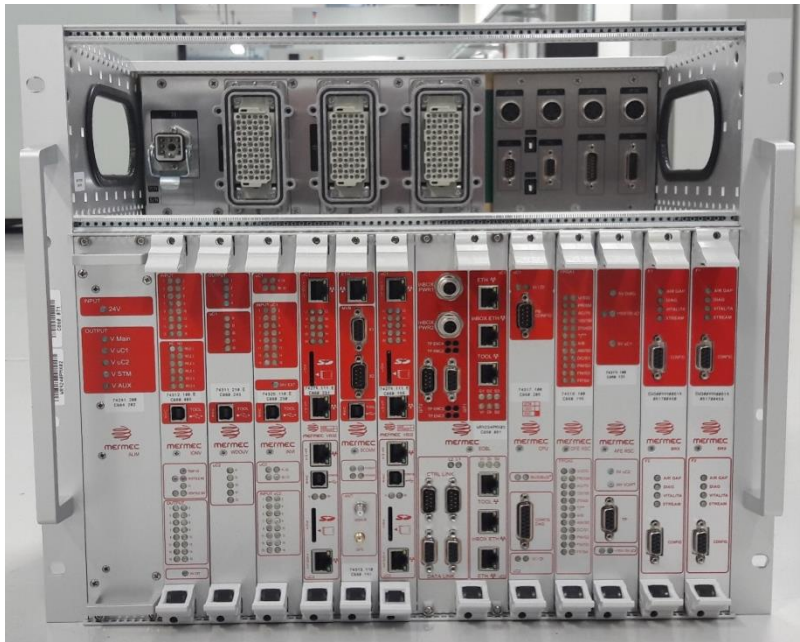

- Baseline3 3.4.0 szoftververzió
- DMI-ba integrált EVM kijelzés
- 2 eszköz / motorvonat
- TELOC 3000 adatrögzítő



**InBox - Odometer
Unterstützung**



DMI

KERNEL



ETCS L2

ETCS L1

SCMT

TIU



ETCS L2

ETCS L1

SCMT

BCOMM



ETCS L2

ETCS L1

SCMT

**BTM
ODO**



ETCS L2

ETCS L1

SCMT

RSC



ETCS L2

ETCS L1

SCMT



KÖSZÖNÖM A MEGTISZTELŐ FIGYELMET!

STADLER