

Infrastrukturális projektek ütemezésének és kontrolljának új lehetőségei

HAJDU Miklós

BME Építéskivitelezési Tanszék



Az apropó...

- A 60. évfordulója a modern tervezési technikáknak
 - Program Evaluation and Review Technique (PERT) 1957
 - Critical Path Method (CPM) 1957
 - Precedence Diagramming Method vagy MPM 1959, 1961, 1964



Megyeri híd ciklogram

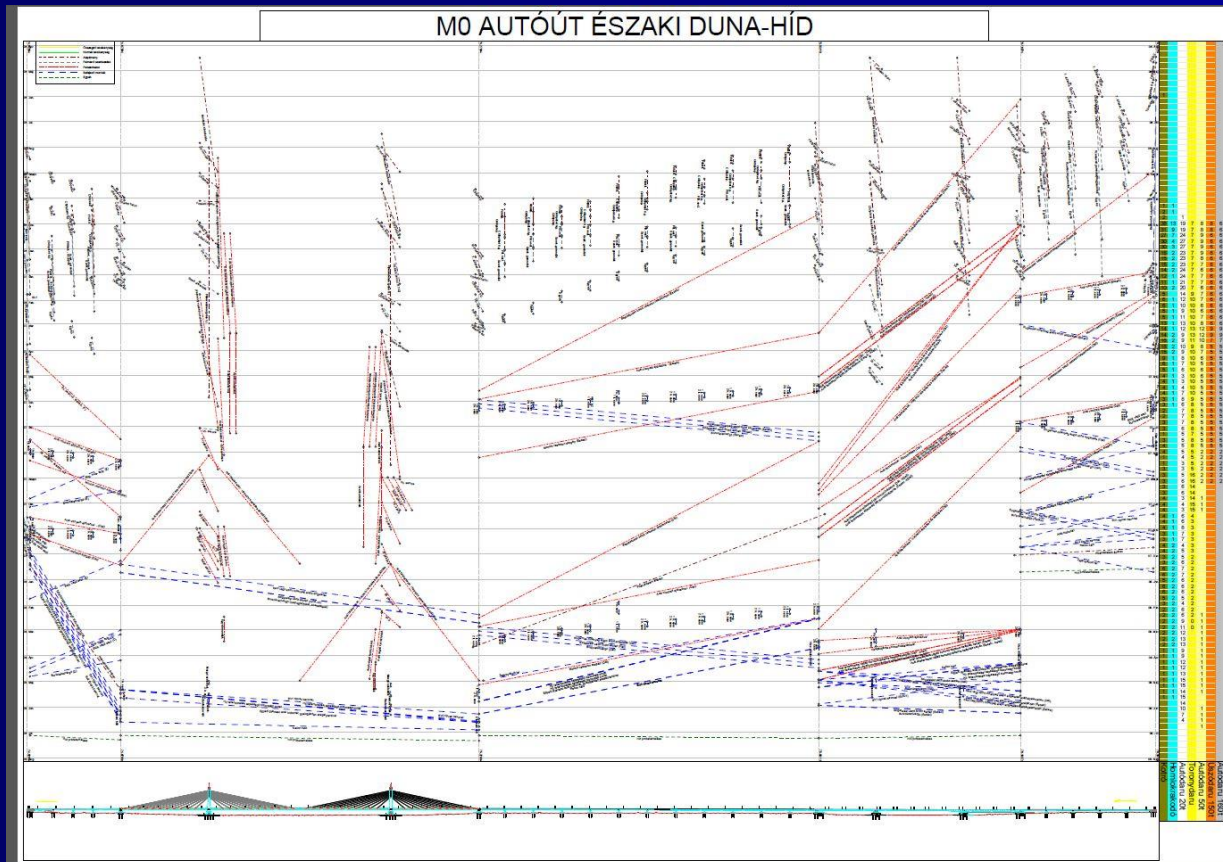

Megyeri híd ciklogram

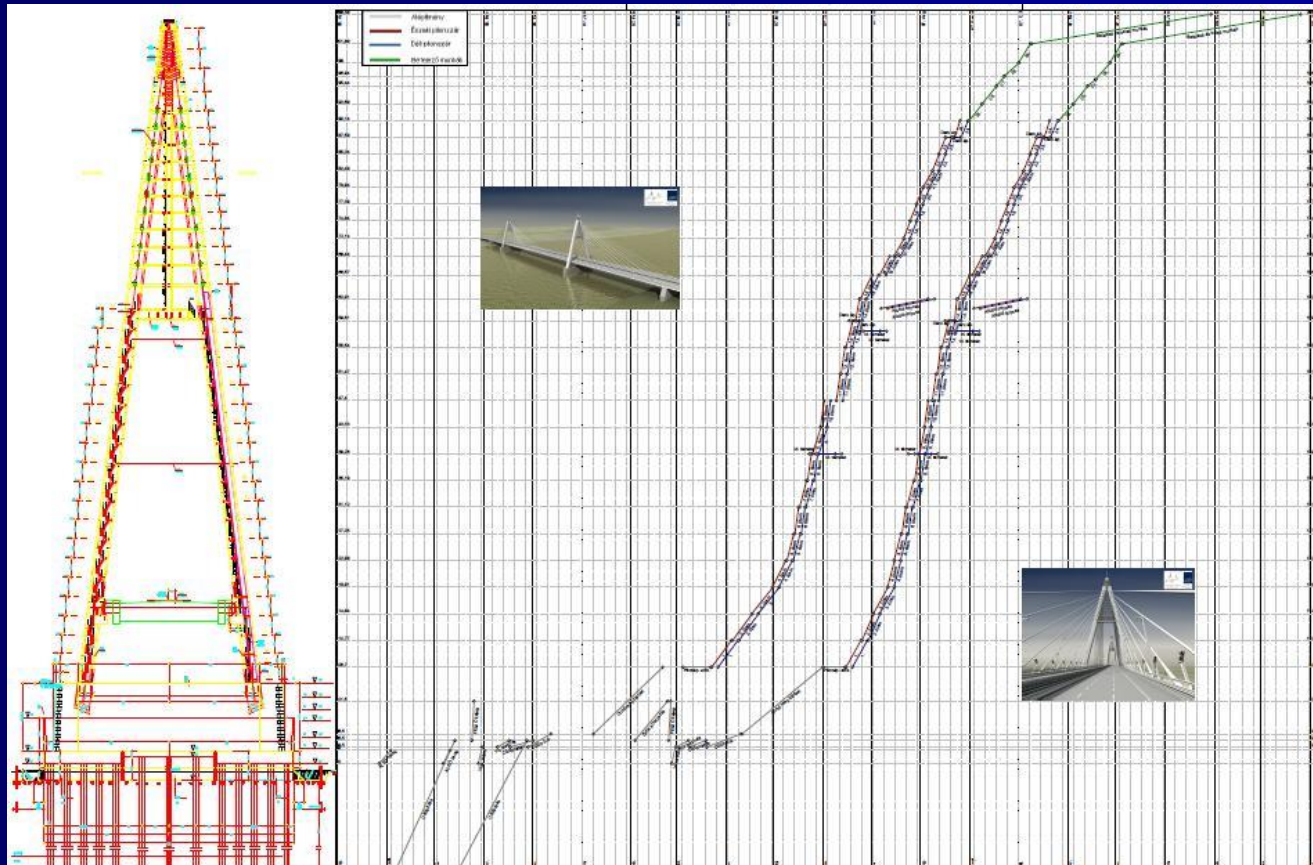

Néhány megoldhatatlan probléma

- Problem #1 (P1)
- Problem #2 (P2)
- Problem #3 (P3)
- Problem #4 (P4)



Problem 1

- A dúcolás (B2) rögtön kezdődhet a munkagödör kieemelése után (B1)
- A dúcanyag más tevékenység befejezése után szállítható a helyszínre (A)



Problem #1 .

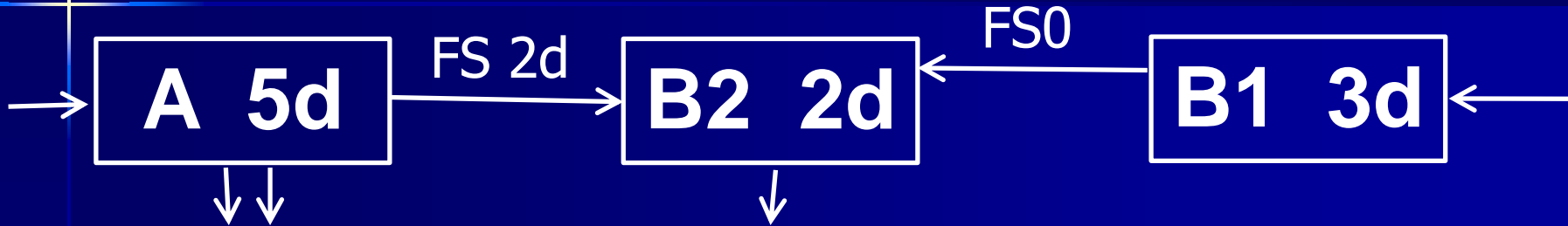

activities

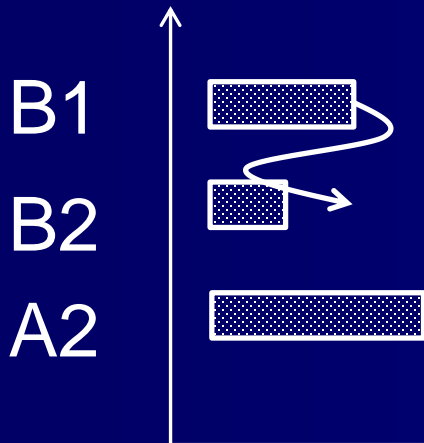

time



Problem #1 ..

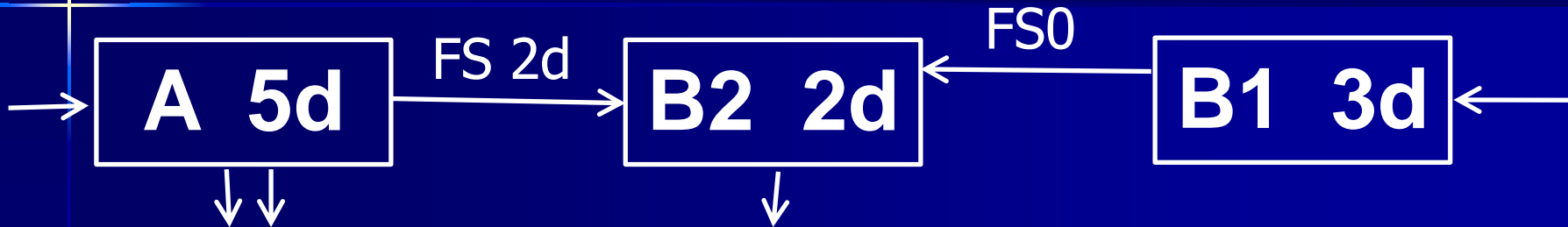

- A dúcolás kezdődjön el a földmunka befejezése után két napon belül!
- Ez hogy modellezhető?



Problem #2 .

- Átlapolás negatív időközzel (e.g. FS-2)

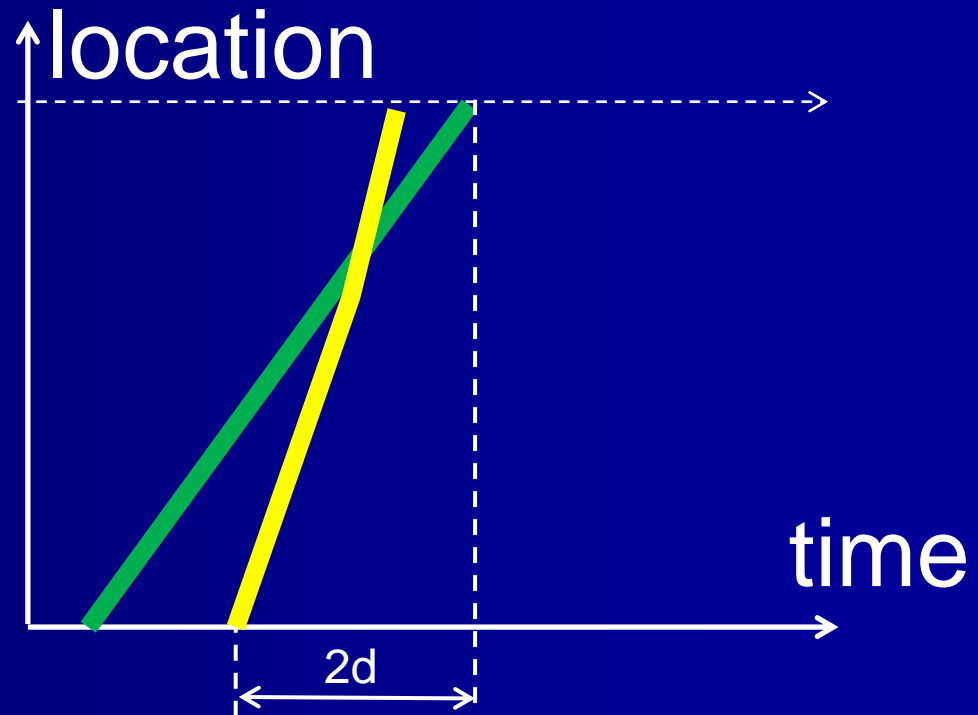
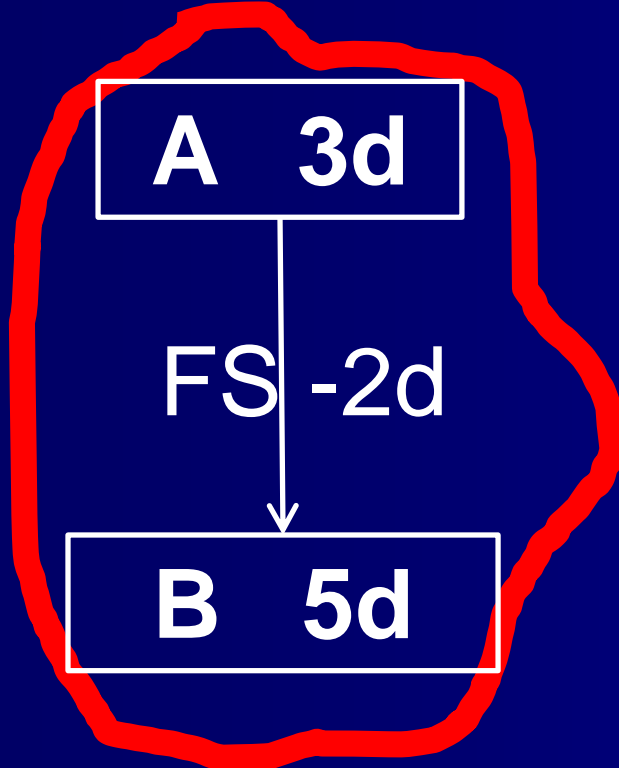

Problem #2 ..

- Átlapolás FF SS kombinációval

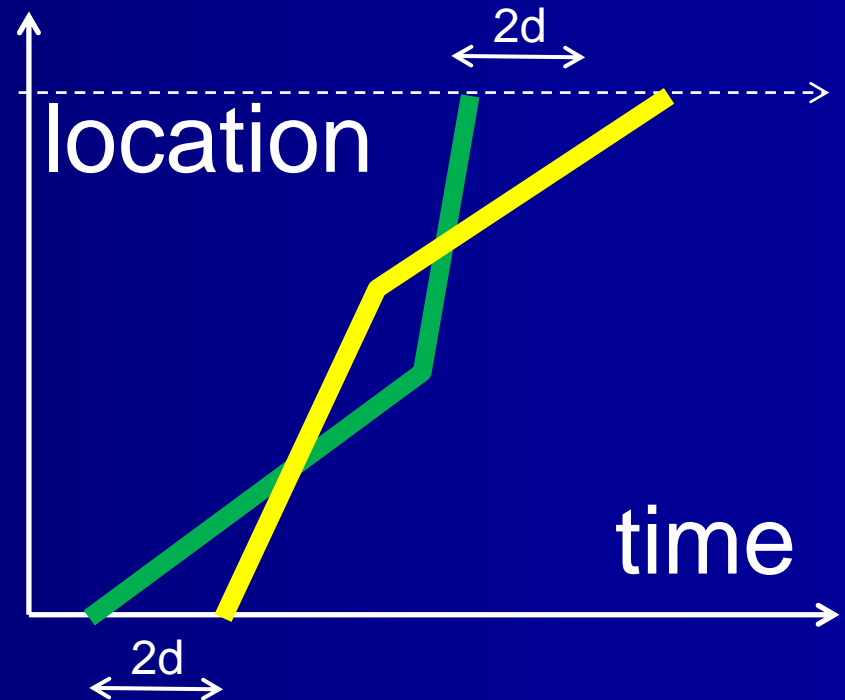
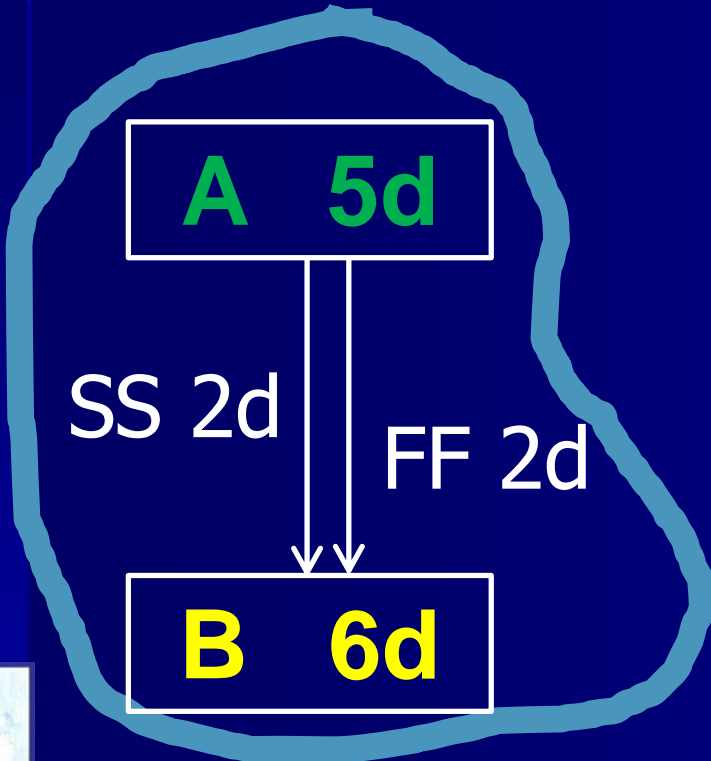

Problem #2

- Átapolás a tev. felbontásával

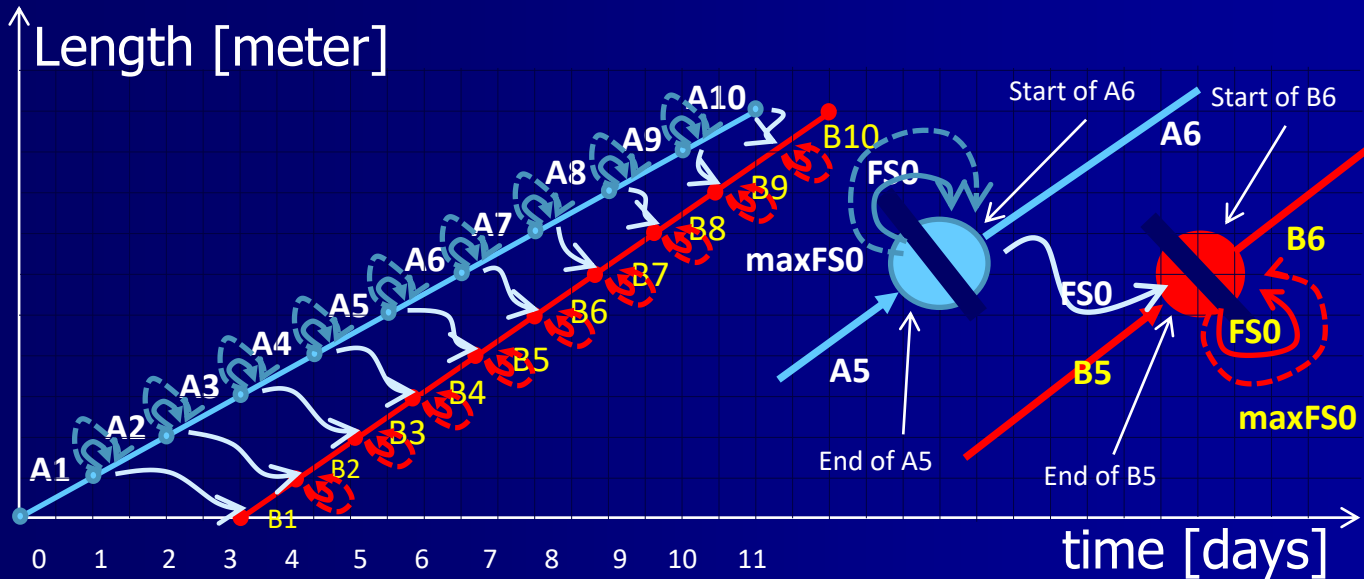
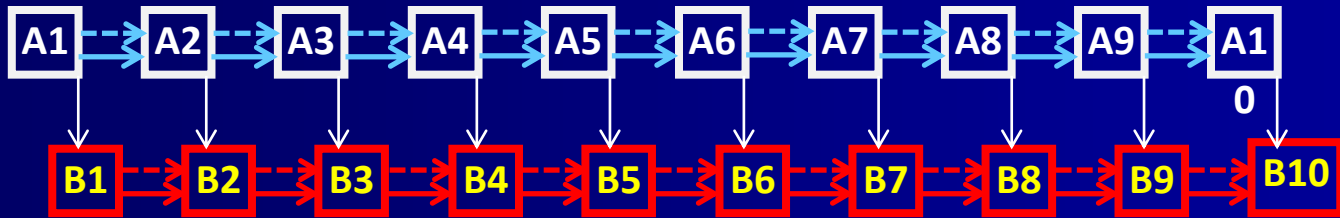

Problem #2

- Van jobb megoldás?



Problem #3

- Három helyen folyik a betonozás egy új recept alapján (A, B, C). A mintavételt (T) olyan gyorsan kell megtenni, ahogy csak lehet.



Problem #3 .

A EF=10

B EF=13

C EF=9

ES=? T

A T kezdete 9. De mi a kapcsolatok?



Problem #4

- Egy brigád van a földkiemelésre. A projektet olyan gyorsan kell befejezni ahogy csak lehet. MI a kapcsolat?



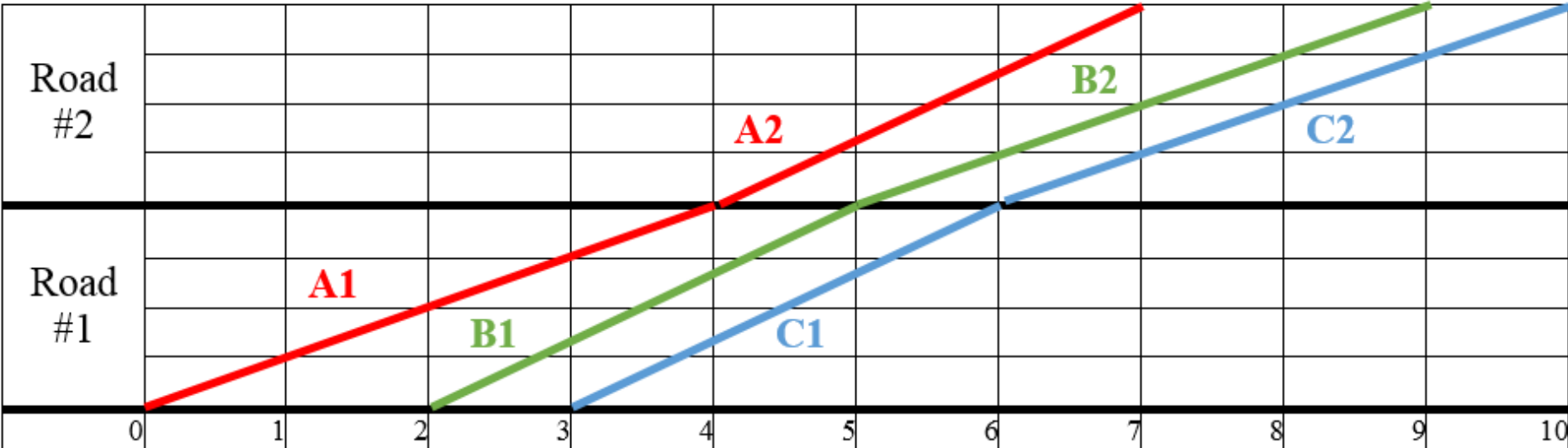

Figure 1. A2 follows A1

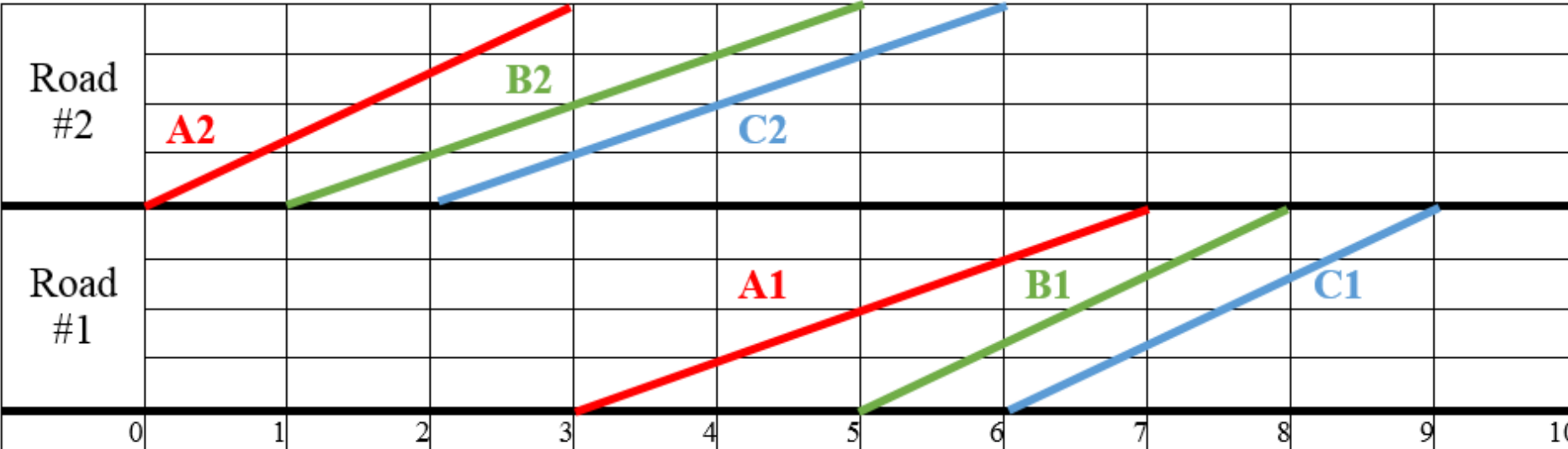

Figure 2. A1 follows A2



Problem #5

- A tevékenységek nem lineárisak és nem csak az elejénél lehet kezdeni rajtuk a munkát.



Problem #1

- Maximális kapcsolatok



#P1...

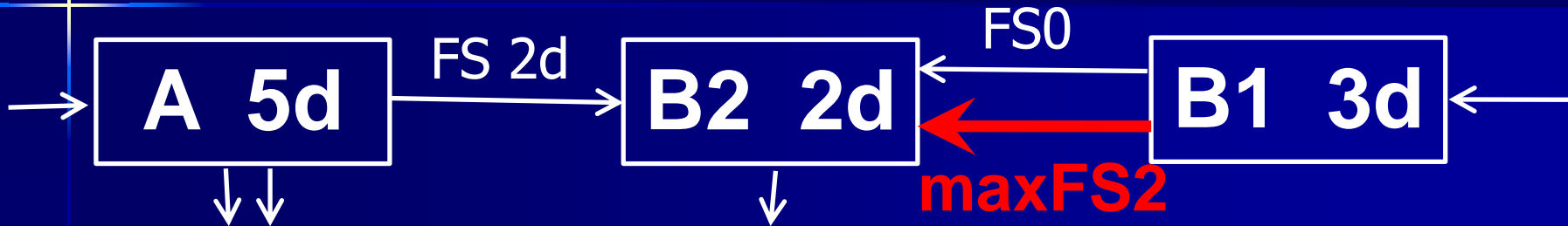

activities

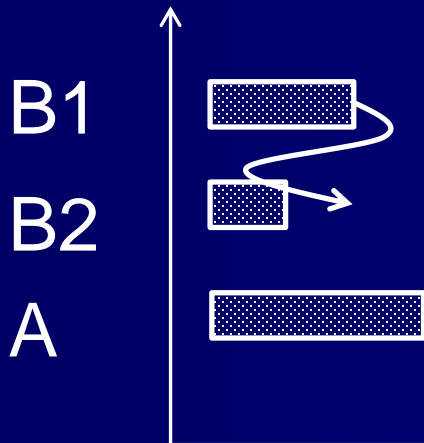

maxFS2

time



#1...

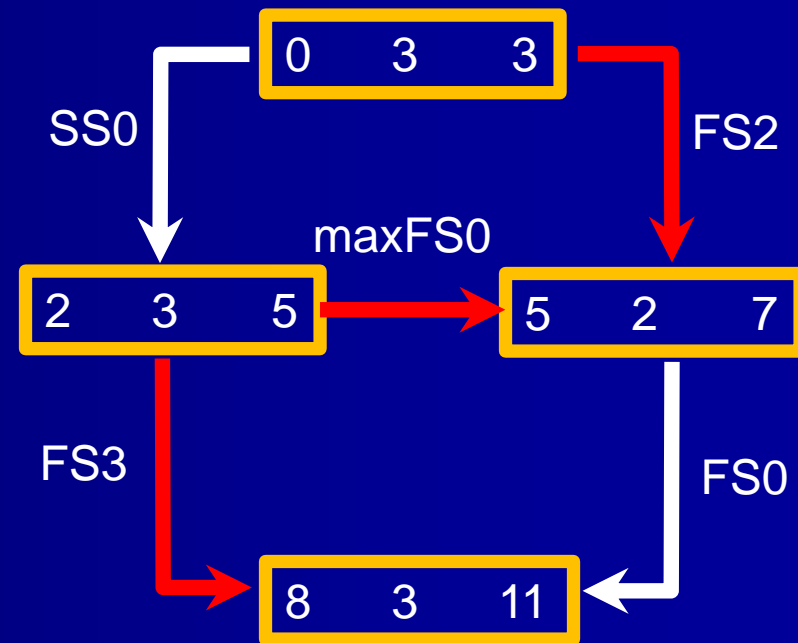
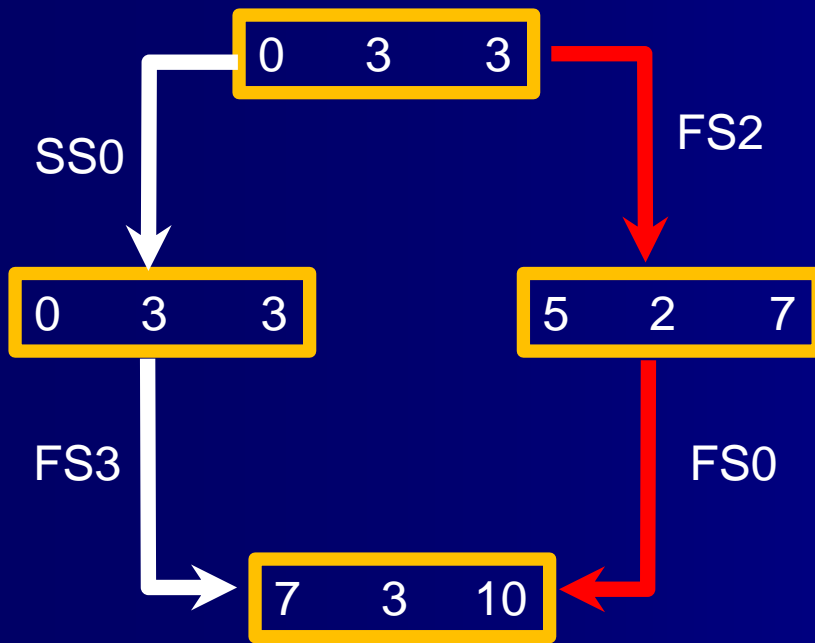

#2 Point-to-point kapcsolatok

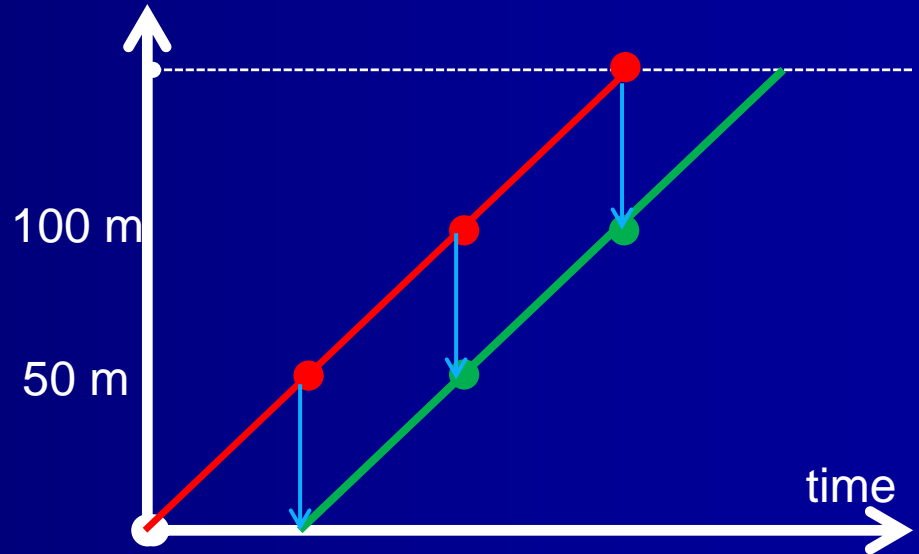
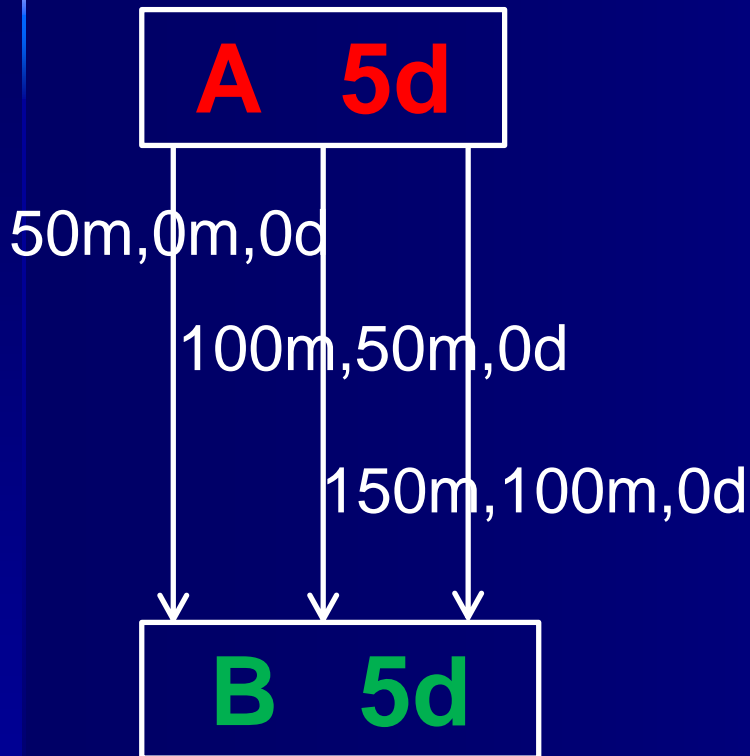

Solution for P2

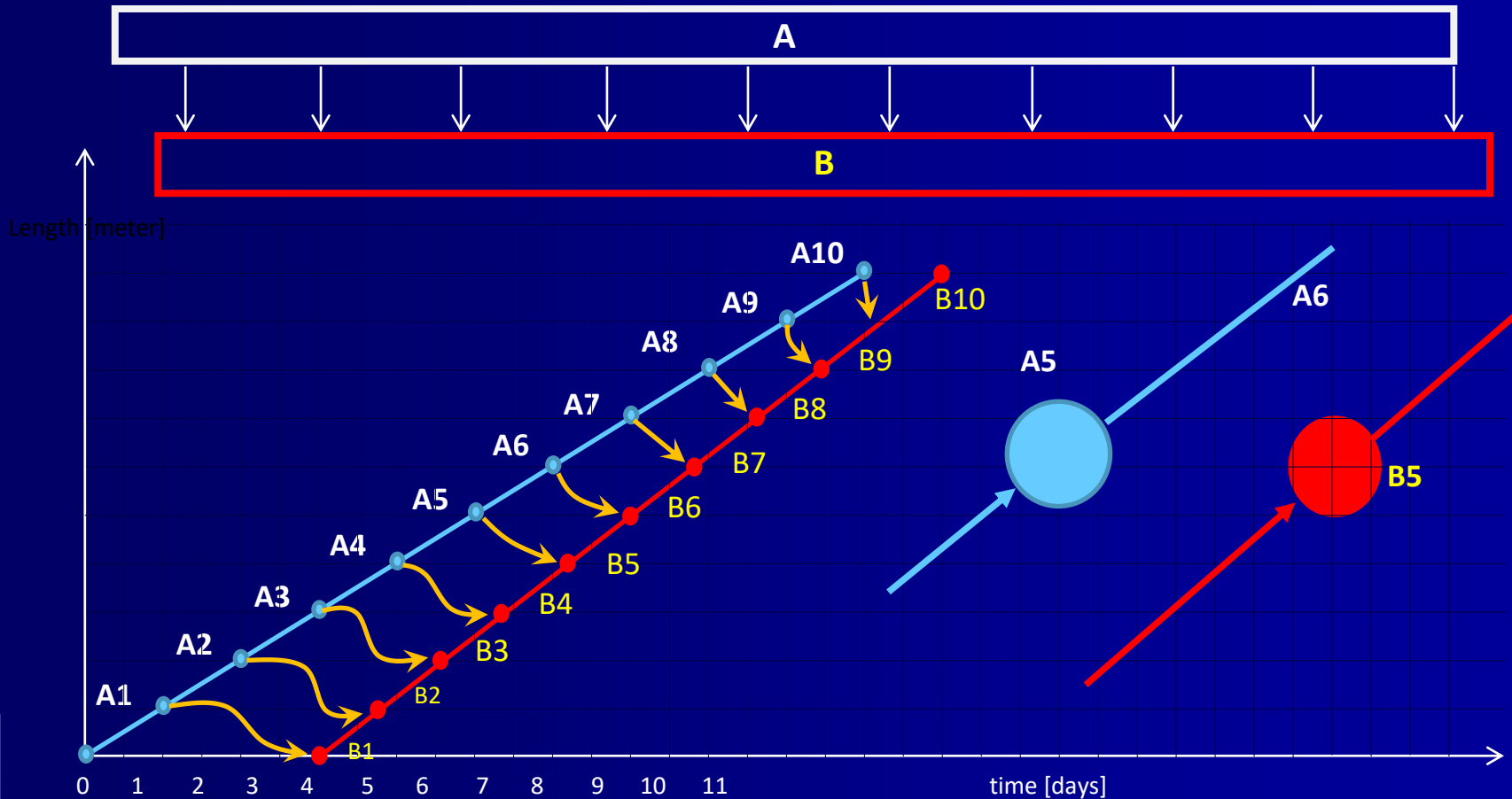

9:34 AM

#P2

Folytonos kapcsolatok

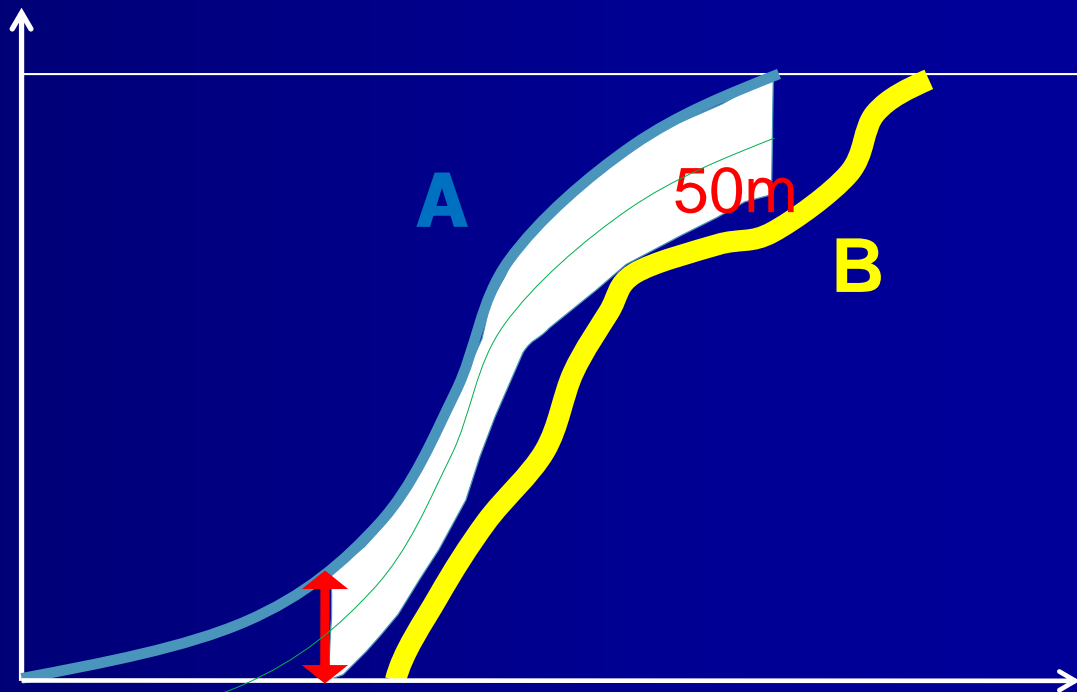
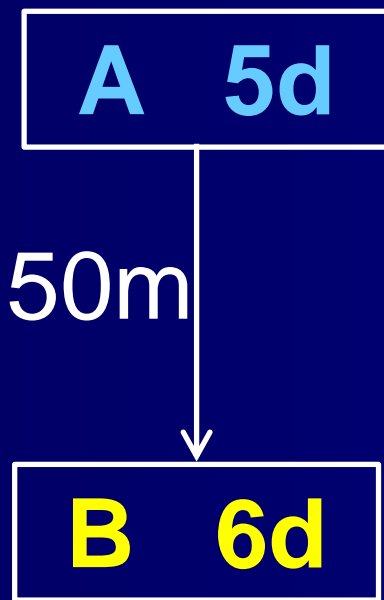

P2

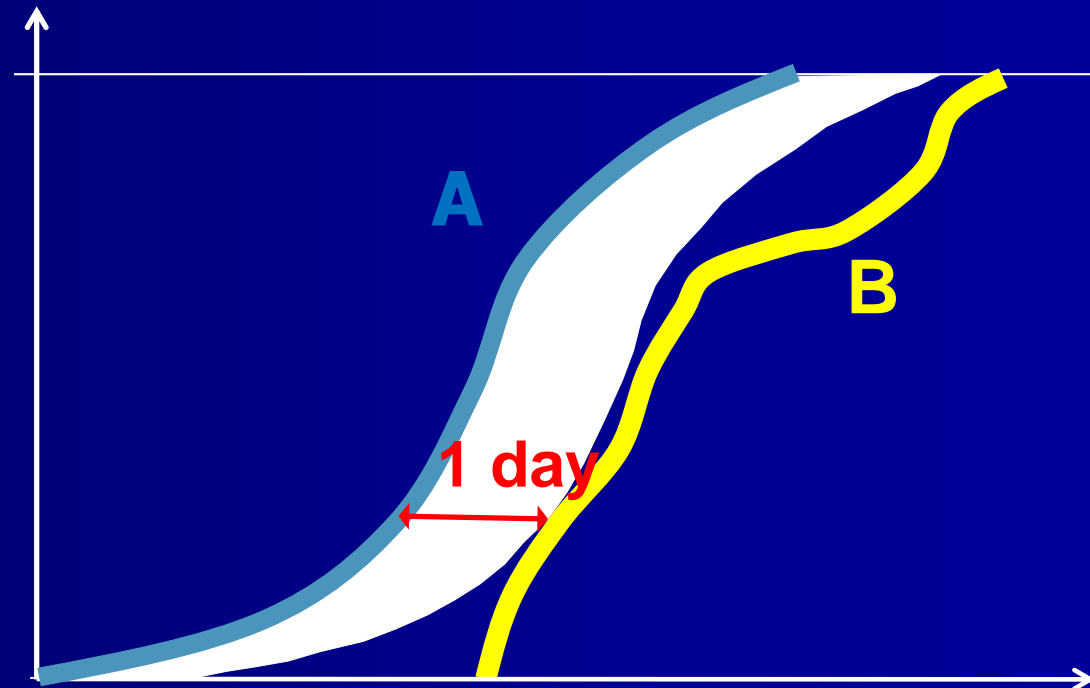
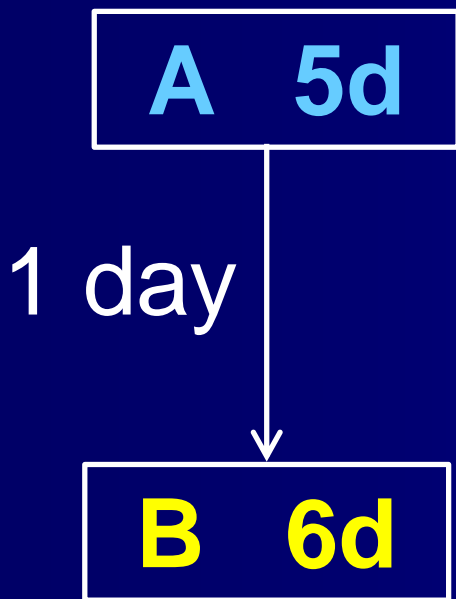

#P3

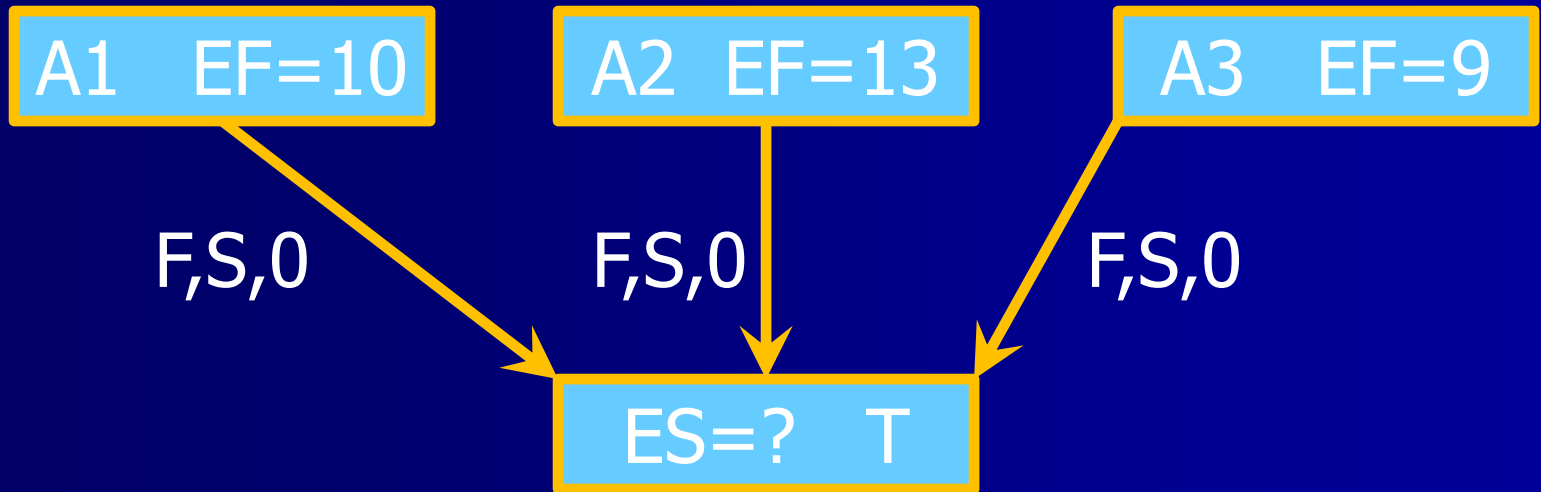

A hagyományos kapcsolatok AND kapcsolatok



#P3

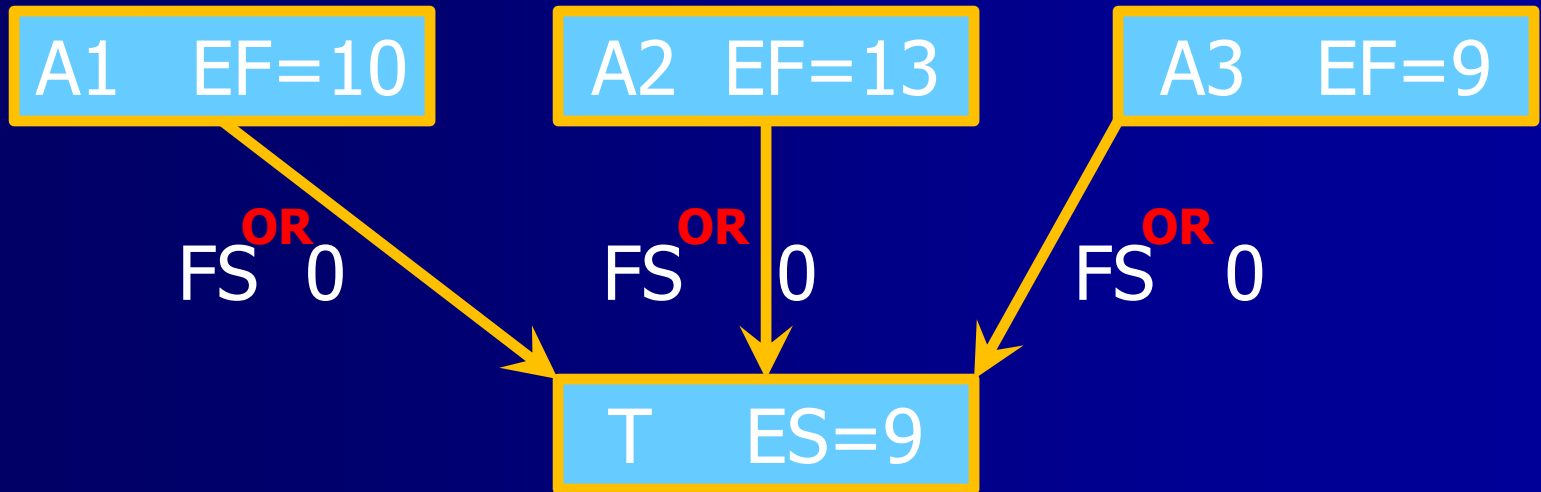

Ezek meg OR kapcsolatok



#P4



- A Kétirányú kapcsolatok



A jövő

A mesterséges intelligencia



Köszönöm a figyelmet !!!

